



AutoCAD[®] MEP 2012

What's New

Case Technologies, Inc.

Courtesy of Burns & McDonnell

Top Features

AutoCAD® MEP 2012 Software

Improved Usability

Increase productivity

- Associative Arrays
- Multifunctional Grips
- 3D Modeling Enhancements
- Command line Enhancements
- Optimize Performance

Drafting Productivity

Automate drafting tasks

- Routing Enhancements
- Auto layout Enhancements
- Tool-based UI
- HVAC Engineer Units

Enhanced Collaboration

Minimize design coordination errors

- IFC Data Support
- AutoCAD® Content Explorer™
- AutoCAD® WS Web and Mobile Applications
- Autodesk® Exchange

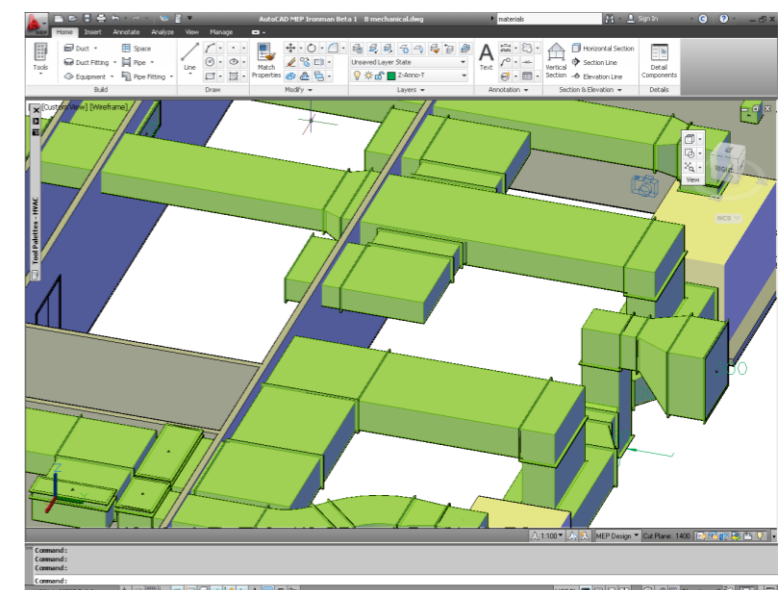
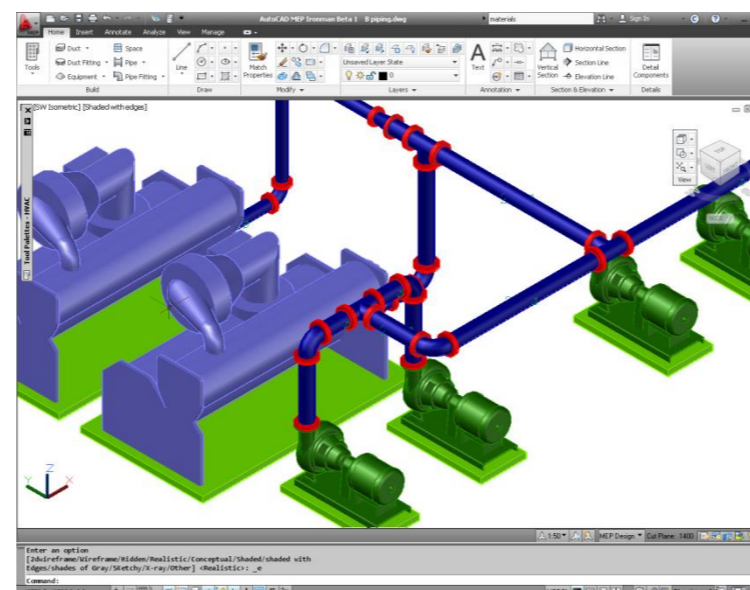
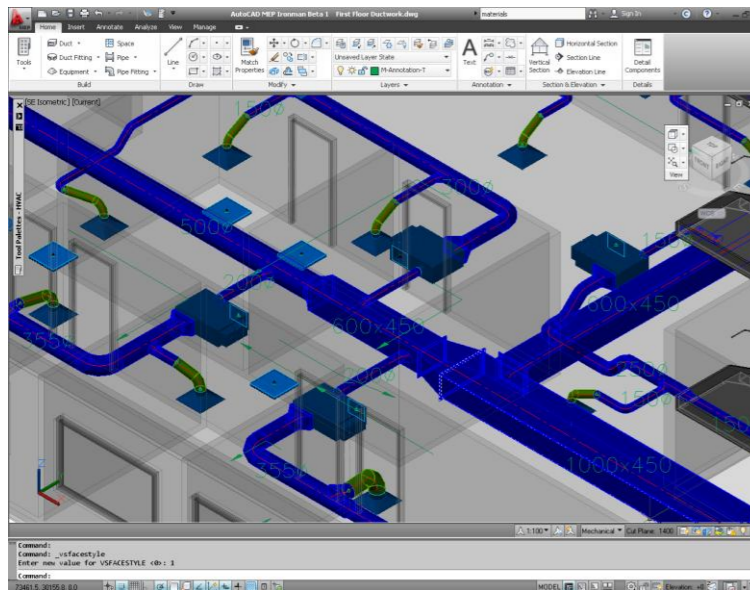

Improved Usability

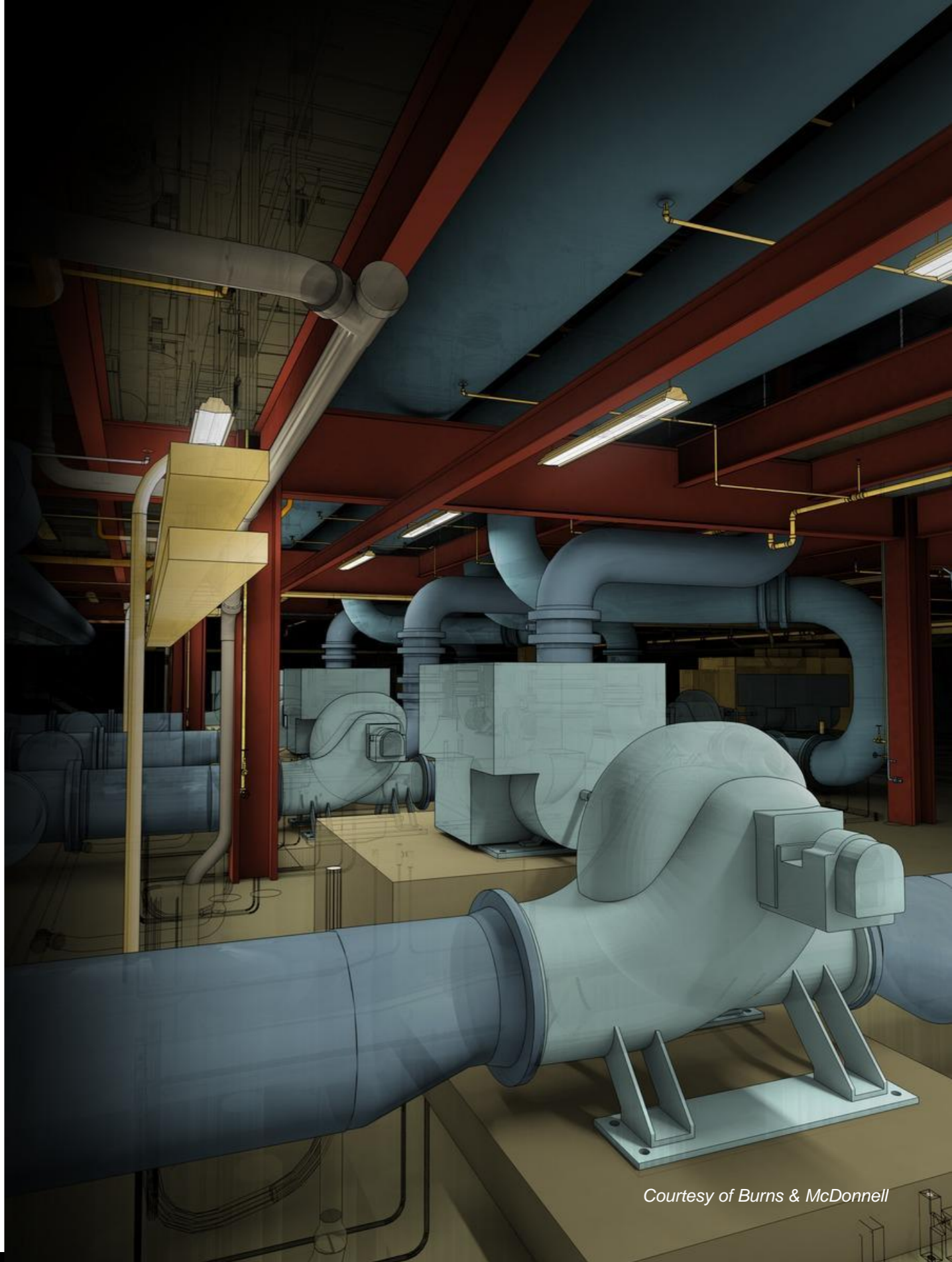

Courtesy of Burns & McDonnell

Improved Usability

AutoCAD MEP 2012

2D and 3D Associative Arrays

- Rectangular
- Path
- Polar

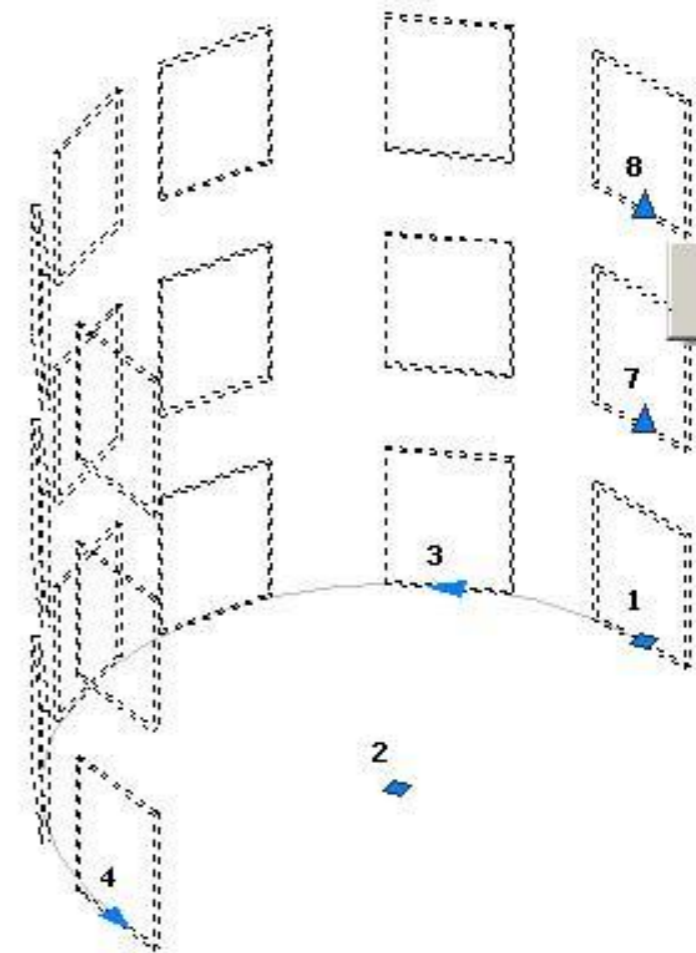
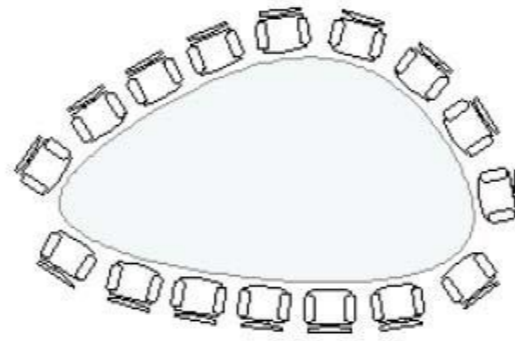
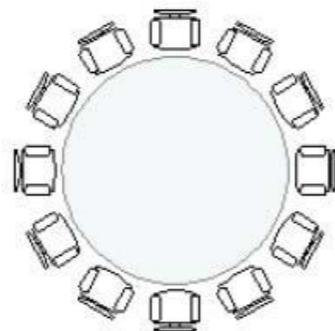
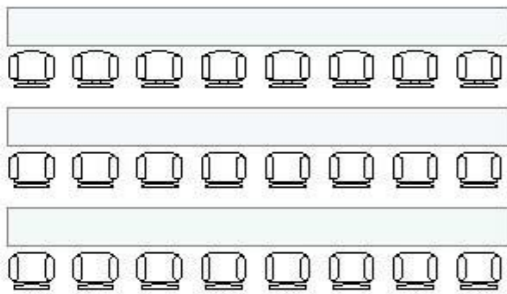

Lay out complex designs more easily with enhanced functionality

Improved Usability

AutoCAD MEP 2012

Multifunctional Grips

- Extend multifunctional grips to additional objects
- Provides direct access to existing functionality
- Edit values with dynamic input enabled

*Modify designs more quickly
using the new grip functionality*

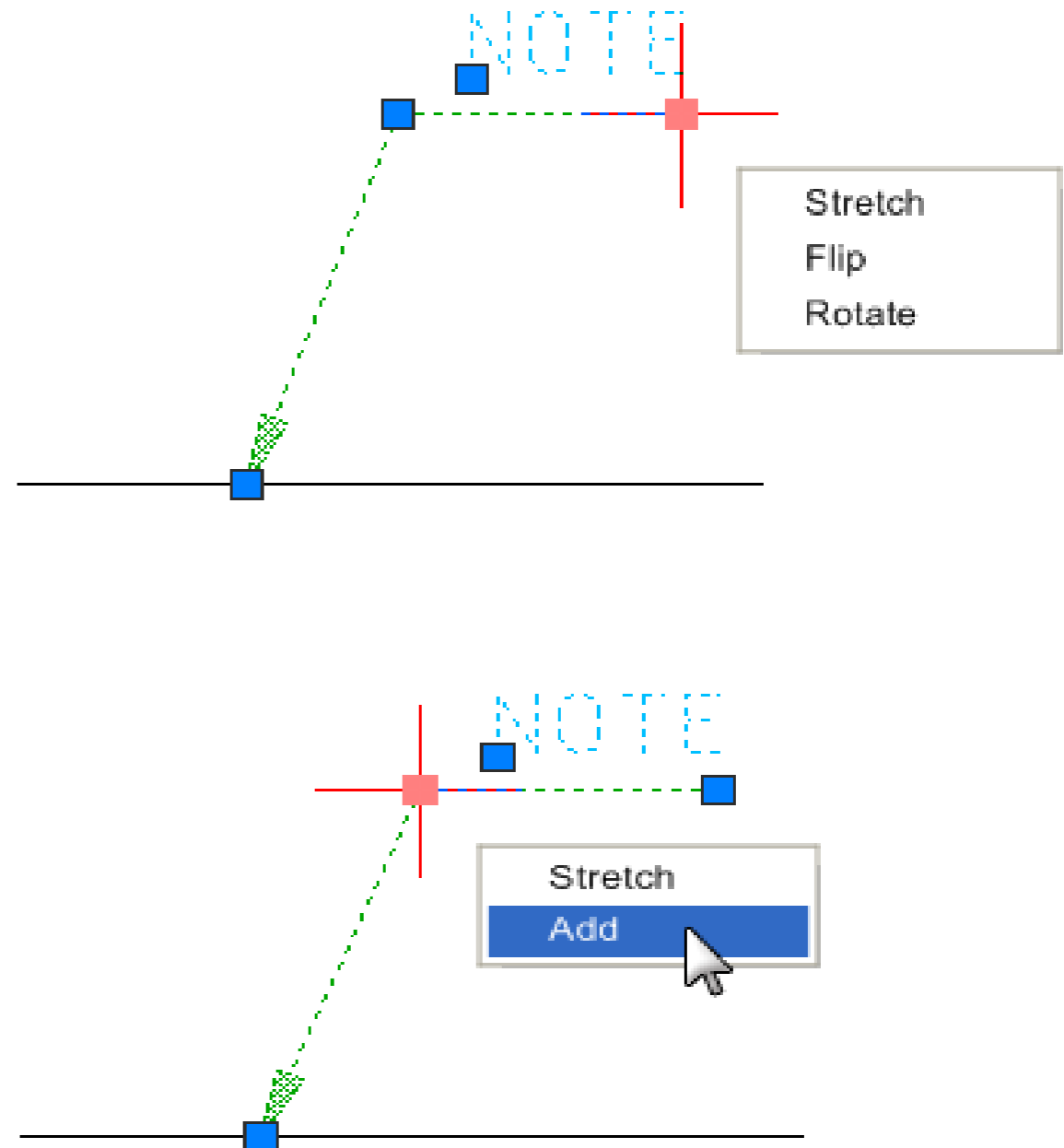

Improved Usability

AutoCAD MEP 2012

3D Modeling Enhancements

- Chain and loop selection
- Presspull functionality
- Offset command

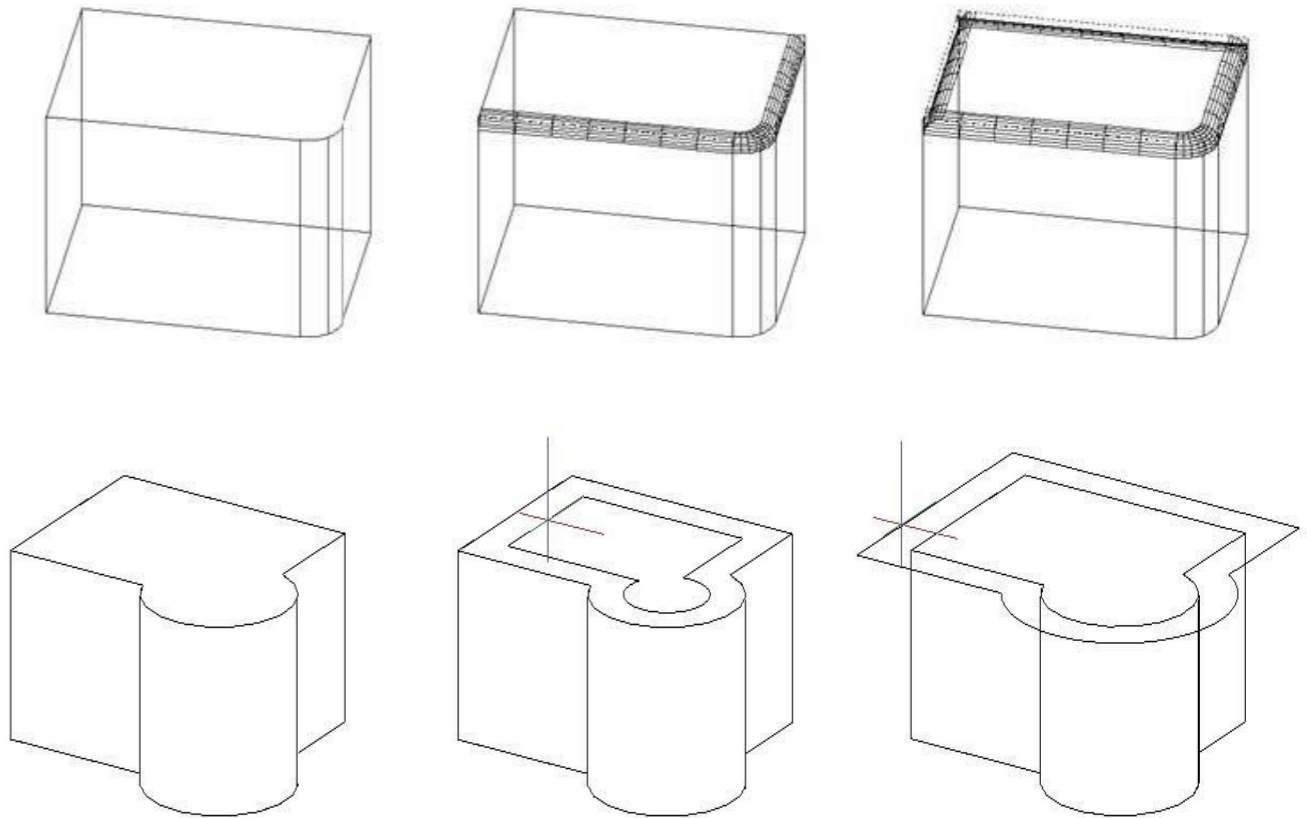

*Use new functionality to help create
MvParts and other design content*

Improved Usability

AutoCAD MEP 2012

Command Line Enhancements

- AutoComplete
- Auto-Append
- Suggestion list
- Dynamic input support
- Right-click menu integration

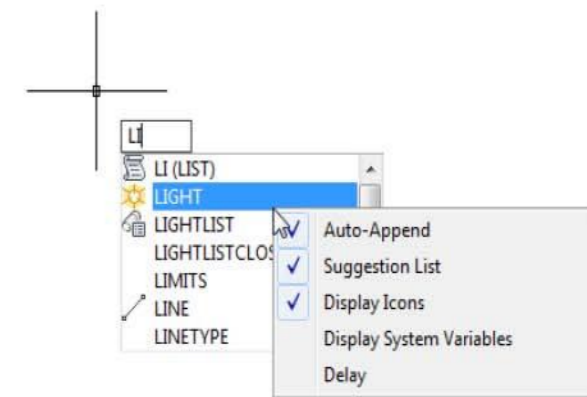
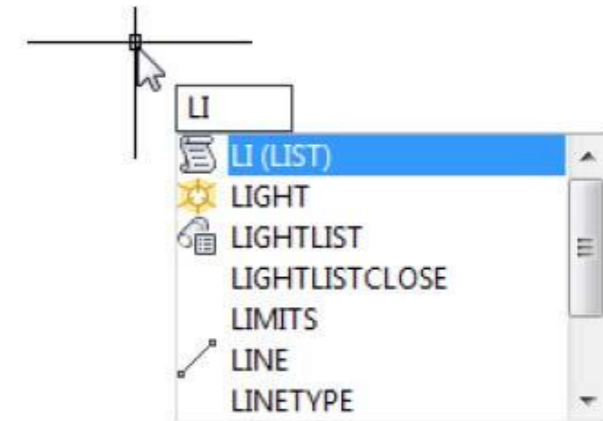
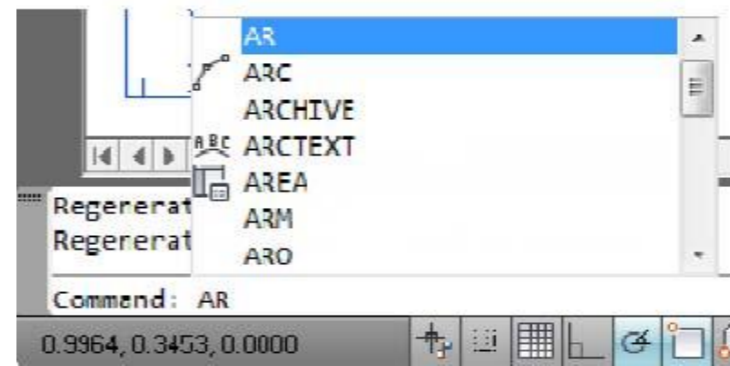

Increase your productivity with tools that support your workflow

Improved Usability

AutoCAD MEP 2012

Optimize Performance*

- ~25% faster application startup
- ~30% faster navigating large designs
- ~40% faster accessing tools
- ~50% faster sections

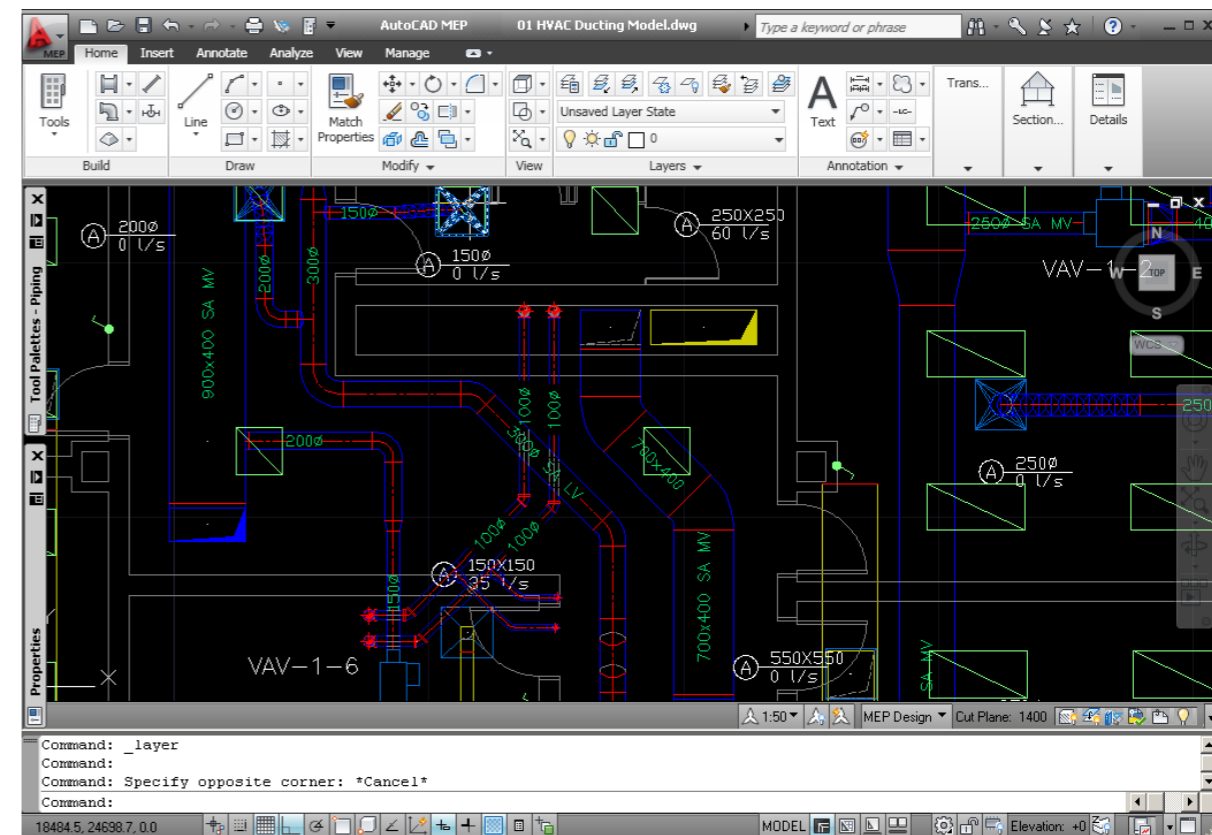

Improved overall performance with faster startup and easier handling of large design files

*Performance study conducted by Autodesk. Actual data throughput will vary with different models.

Drafting Productivity

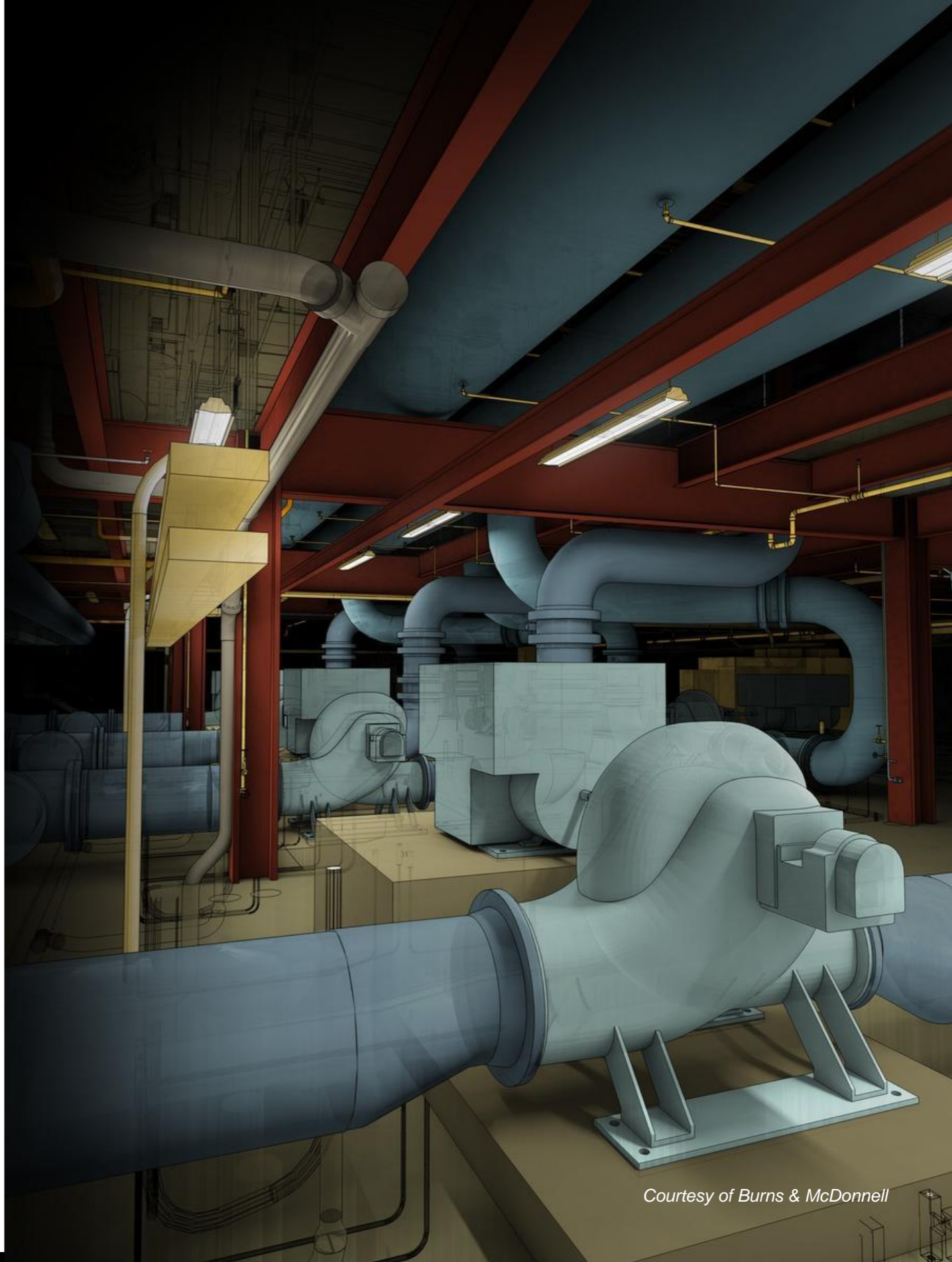

Courtesy of Burns & McDonnell

Drafting Productivity

AutoCAD MEP 2012

Routing Enhancements

- Bend method
- Detour routing
- Narrow passages
- Transitional offset

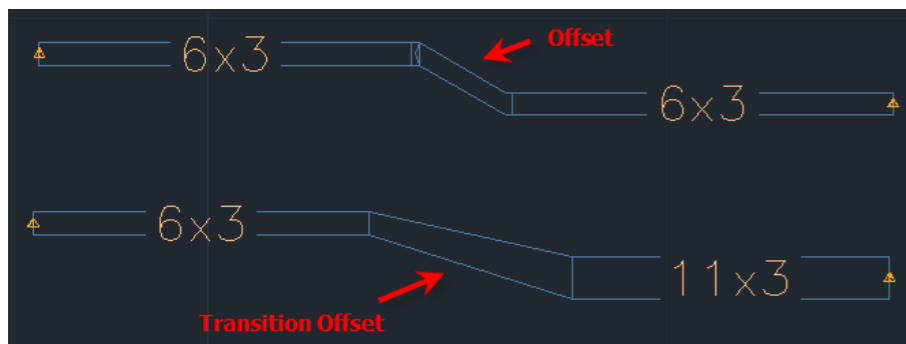
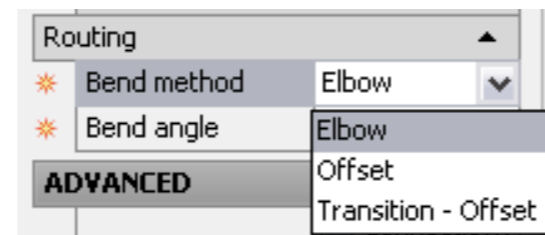
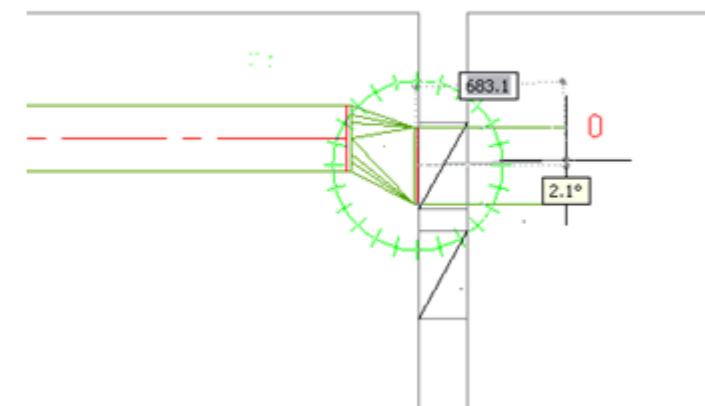
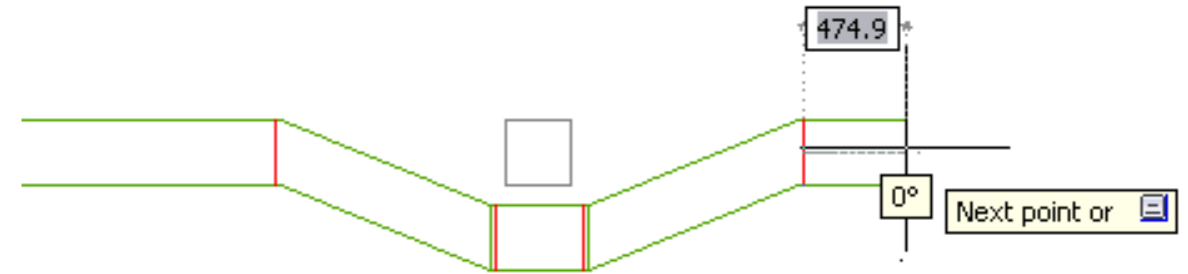

Route duct around obstacles to represent how the system will be constructed

Drafting Productivity

AutoCAD MEP 2012

Auto Layout Enhancements

- Simple offsets
- Simple transitions
- Reducing elbows
- Transition offsets

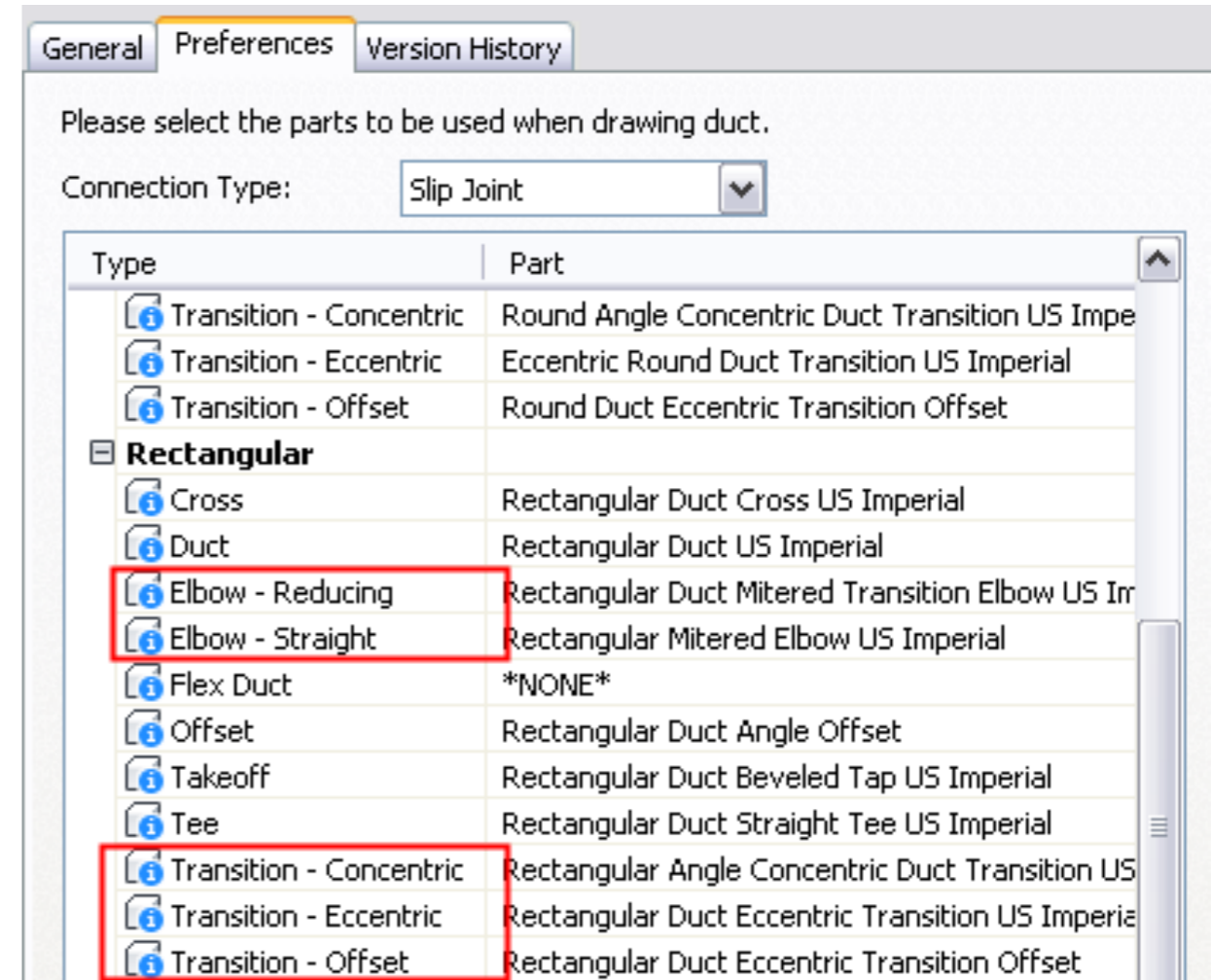

Auto layout tools route duct the same way it would be physically installed

Drafting Productivity

AutoCAD MEP 2012

Tool-based UI

- Properties palette
- Single location
- Consistent interface

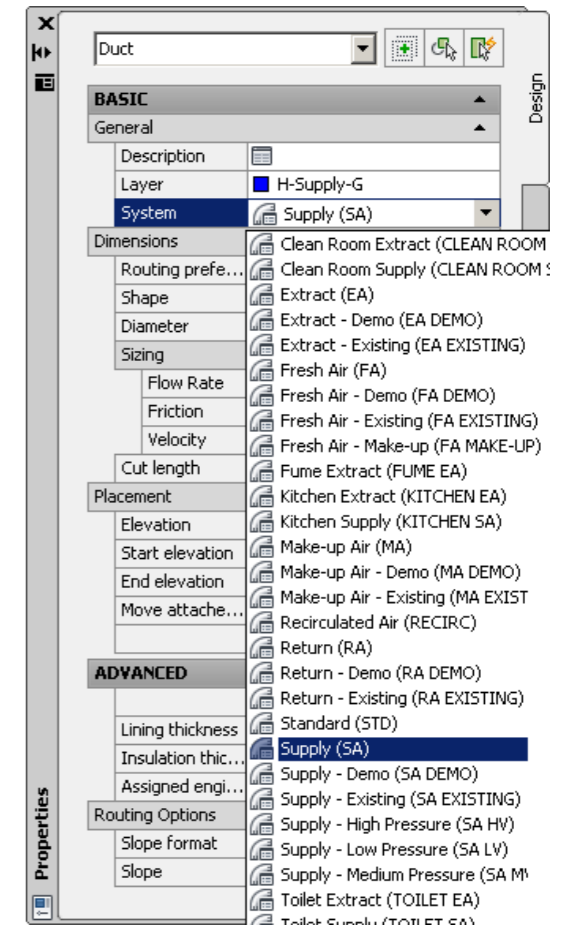
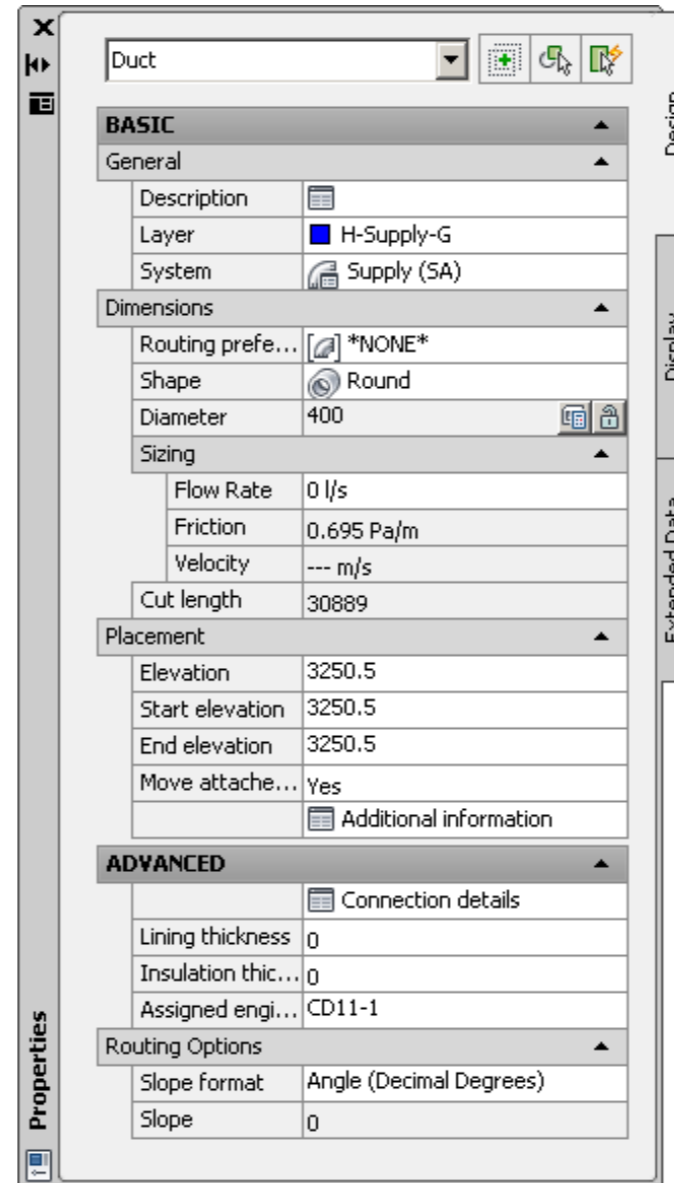

*Save time searching for information—
just look for a single location*

Drafting Productivity

AutoCAD MEP 2012

HVAC Engineer Units

- Flow
- Friction
- Velocity

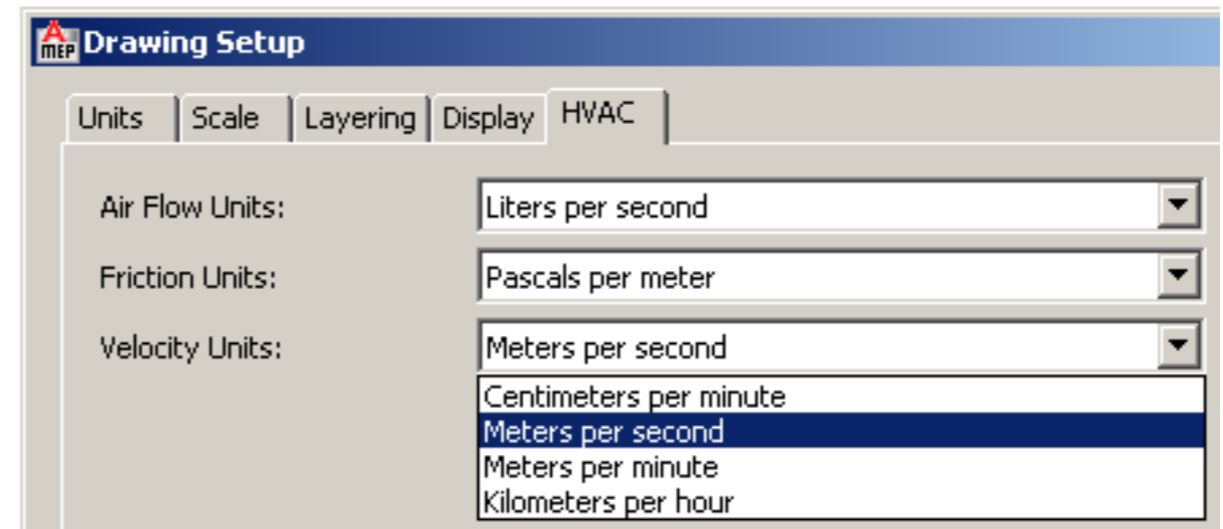
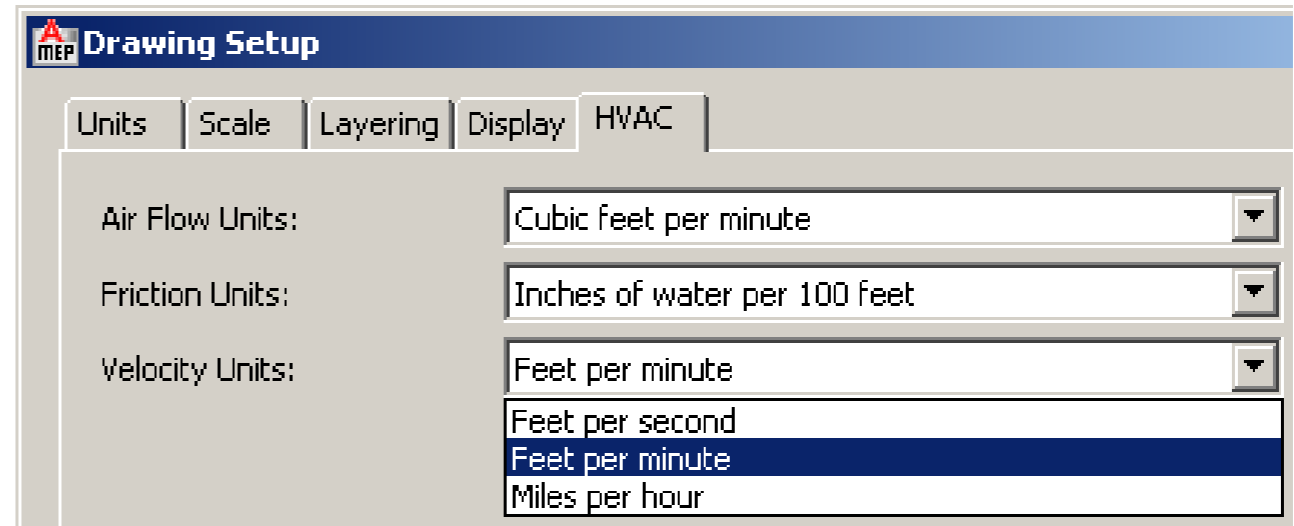

Design more accurately with tools that make it easier to convert engineering units

Enhanced Collaboration

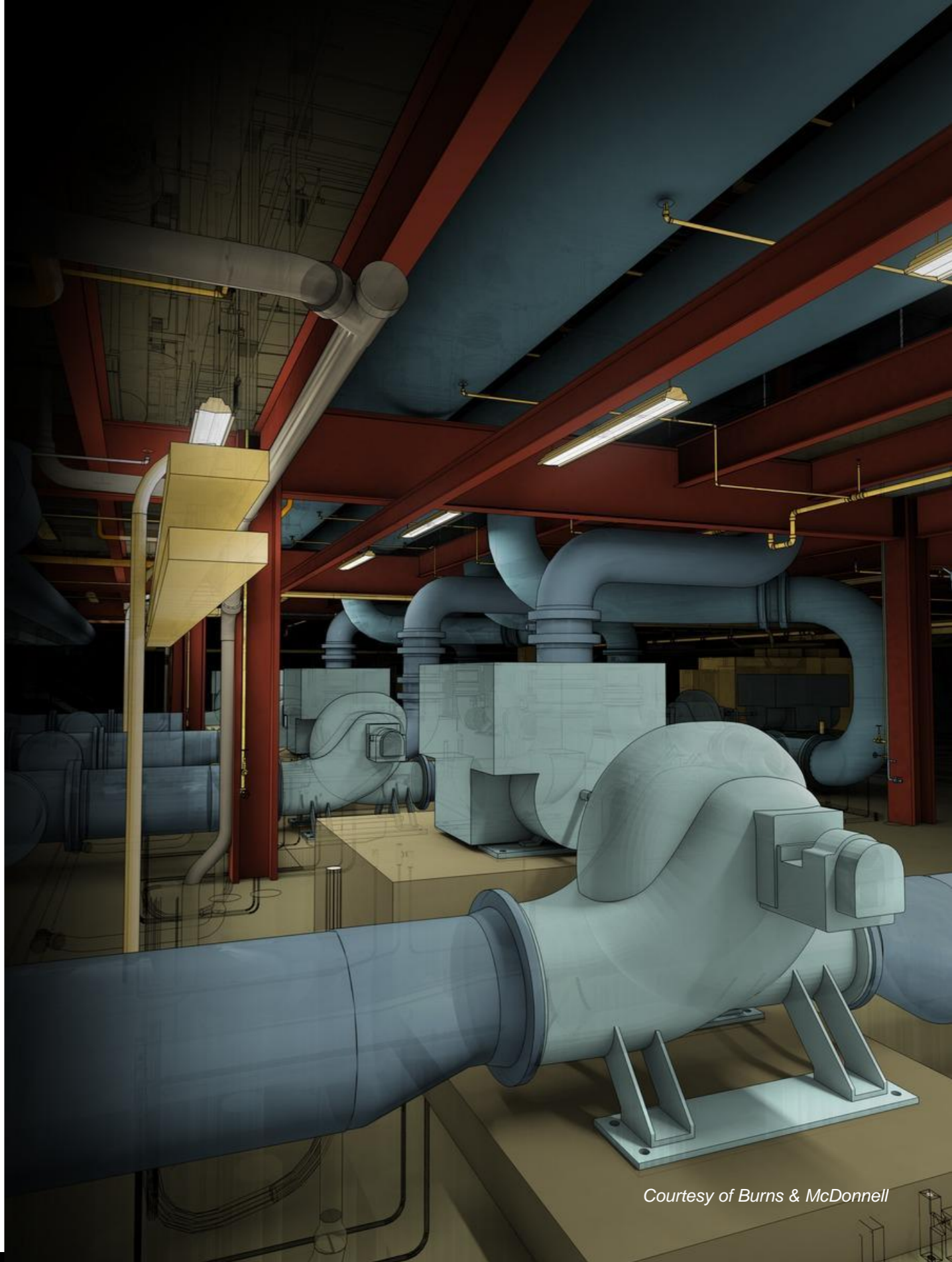

Courtesy of Burns & McDonnell

Enhanced Collaboration

AutoCAD MEP 2012

IFC Data Support

- Recognize MEP objects
- Space boundary information
- Command line access
- New physical quantities

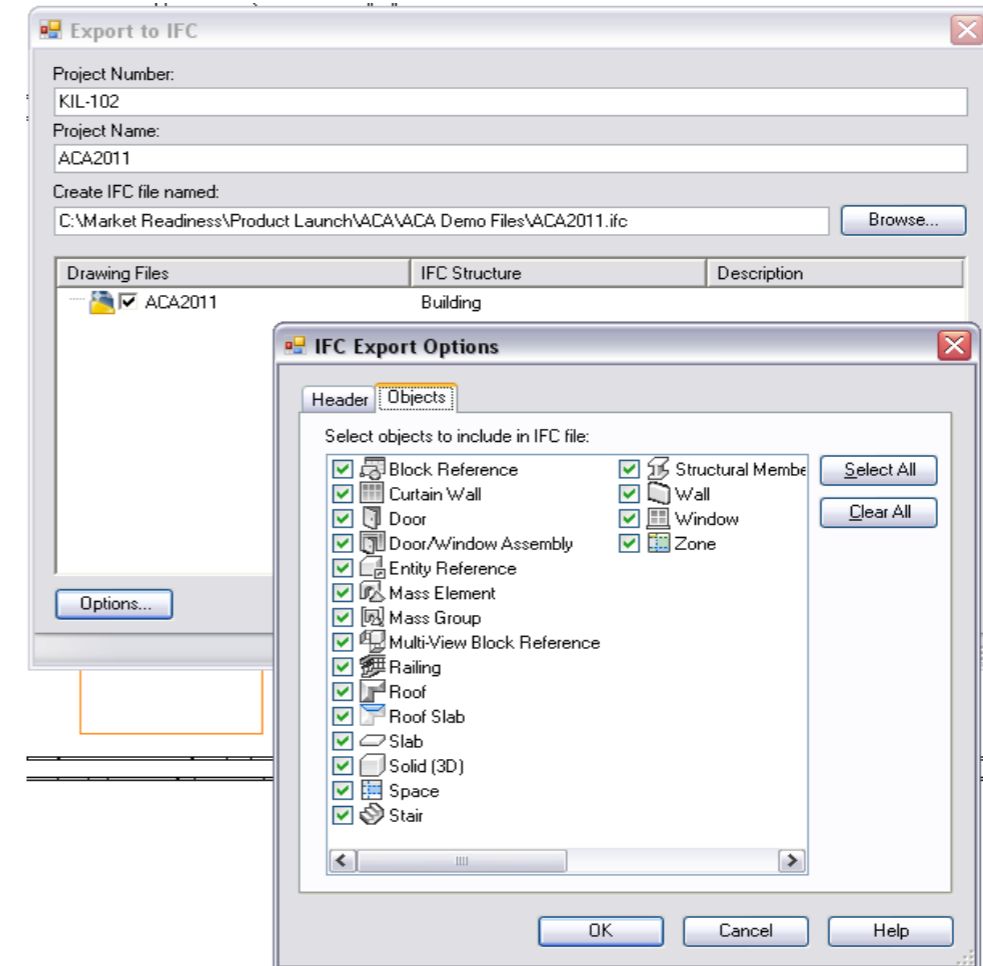

Smoothly exchange more relevant data with team members

Enhanced Collaboration

AutoCAD MEP 2012

AutoCAD Content Explorer

- Access design files, objects, content
- Search local and network drives
- Use content in design environment

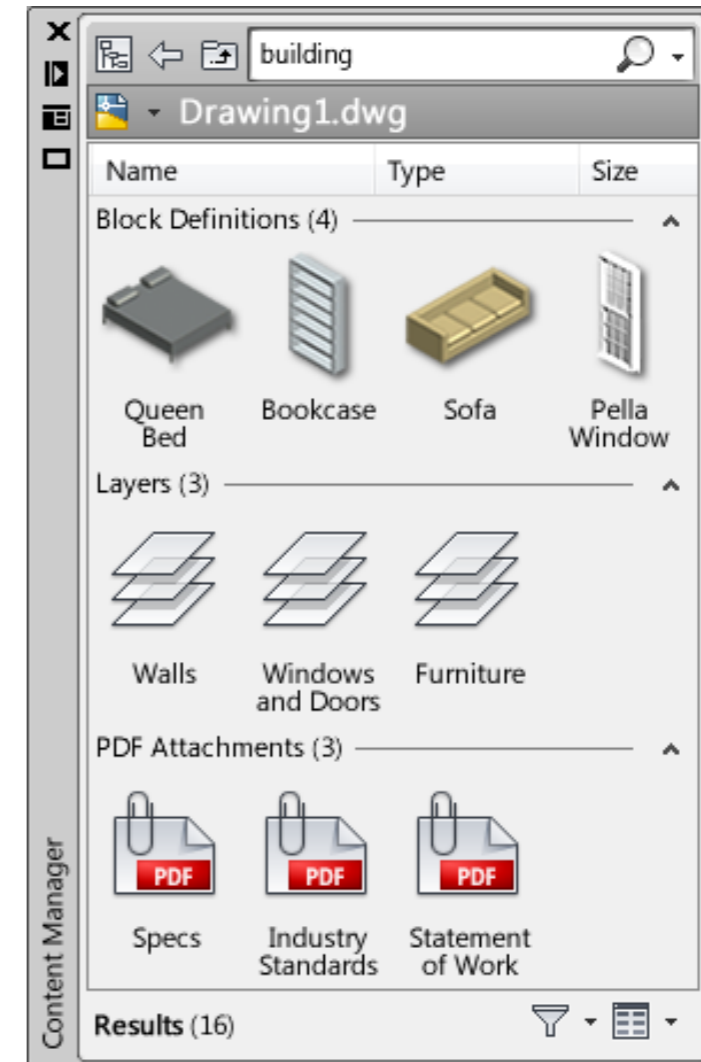
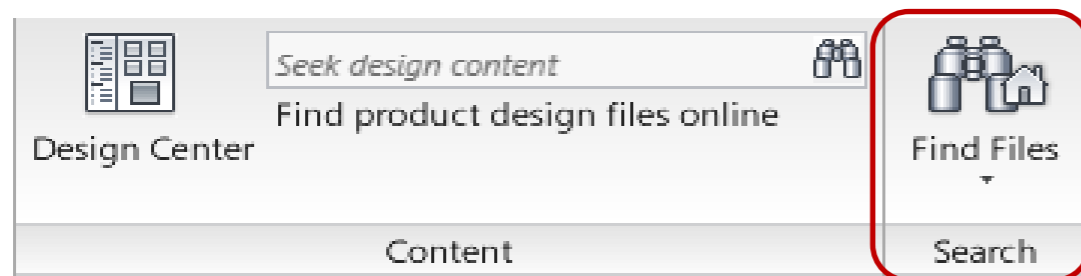

*Quickly access design content
with integrated content search*

Enhanced Collaboration

AutoCAD MEP 2012

AutoCAD WS Web and Mobile Applications

- View, share, and edit from wherever you are
- Stay connected via web or mobile device
- Access directly from user interface

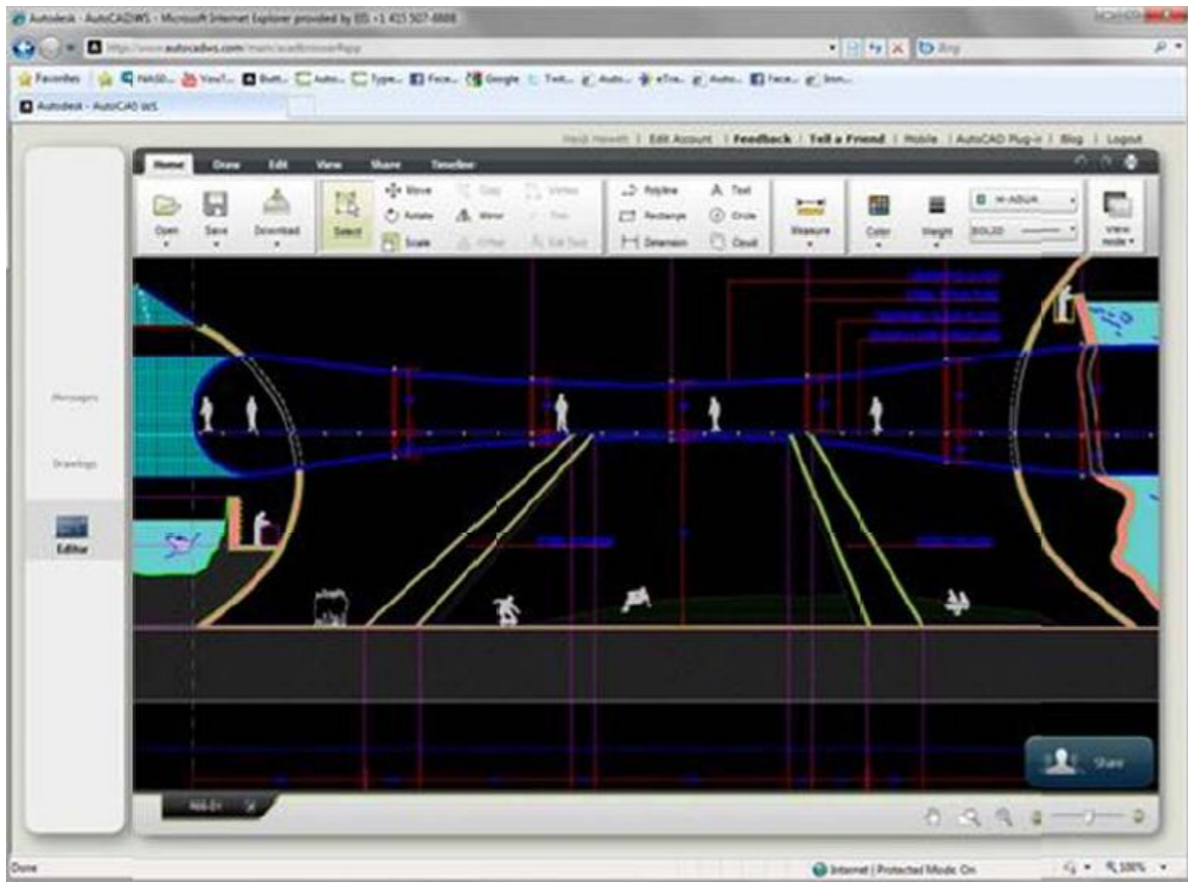

*Freedom to work virtually
anywhere, with anyone on your
extended team*

Enhanced Collaboration

AutoCAD MEP 2012

Autodesk Exchange for AutoCAD MEP

- Access to web-based help content
- Tips and tricks
- Aggregated content

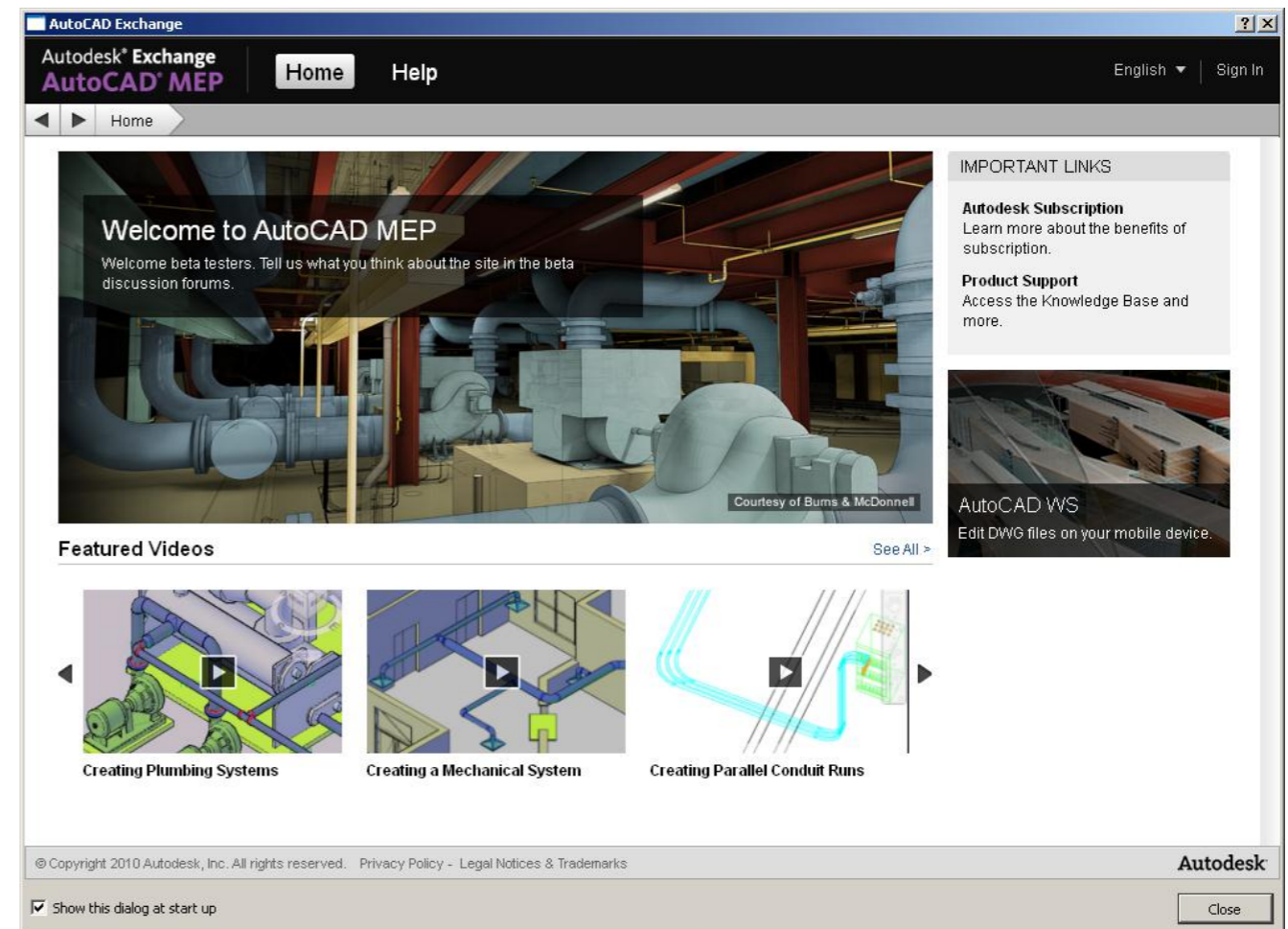

Access a community filled with pertinent learning information

Autodesk Subscription

Discover the Subscription Advantage

Autodesk® Subscription allows customers to extend the value of their software investment with access to the latest releases, powerful web services, and expedited technical support.



AutoCAD MEP 2012

- Improved Usability
- Drafting Productivity
- Enhanced Collaboration



Autodesk®

Autodesk, AutoCAD, and Content Explorer are registered trademarks or trademarks of Autodesk, Inc., and/or its subsidiaries and/or affiliates in the USA and/or other countries. All other brand names, product names, or trademarks belong to their respective holders. Autodesk reserves the right to alter product and services offerings, and specifications and pricing at any time without notice, and is not responsible for typographical or graphical errors that may appear in this document.

© 2011 Autodesk, Inc. All rights reserved.

Autodesk